



ETA-Danmark A/S
Göteborg Plads 1
DK-2150 Nordhavn
Tel. +45 72 24 59 00
Internet www.etadanmark.dk

Authorised and notified according
to Article 29 of the Regulation (EU)
No 305/2011 of the European
Parliament and of the Council of 9
March 2011

MEMBER OF EOTA



European Technical Assessment ETA-23/0166 of 2023/11/28

I General Part

Technical Assessment Body issuing the ETA and designated according to Article 29 of the Regulation (EU) No 305/2011: ETA-Danmark A/S

Trade name of the construction product:

fischer FFB-ES Plus

Product family to which the above construction product belongs:

Fire Stopping, Fire Sealing & Fire Protective Products.
Fire Retardant Products

Manufacturer:

fischerwerke GmbH & Co. KG
Klaus-Fischer-Str. 1
DE-72178 Waldachtal
Telephone: +49 7443 120
www.fischer-international.com

Manufacturing plant:

fischerwerke

This European Technical Assessment contains:

13 pages including 2 annexes which form an integral part of the document

This European Technical Assessment is issued in accordance with Regulation (EU) No 305/2011, on the basis of:

EAD 350141-00-1106 Fire Stopping and Fire Sealing Products, Linear Joint and Gap Seals

Translations of this European Technical Assessment in other languages shall fully correspond to the original issued document and should be identified as such.

Communication of this European Technical Assessment, including transmission by electronic means, shall be in full. However, partial reproduction may be made, with the written consent of the issuing Technical Assessment Body. Any partial reproduction has to be identified as such.

II SPECIFIC PART OF THE EUROPEAN TECHNICAL ASSESSMENT

1 Technical description of the product

fischer FFB-ES Plus is a one-part water based acrylic spray system used to reinstate the fire resistance performance of linear joint gaps in rigid or flexible wall constructions, rigid floor constructions, and perimeter joints in curtain wall façades.

fischer FFB-ES Plus is supplied in buckets and can be sprayed or troweled as a surface-mounted system on a suitable backing material with overlap as specified in Annex B of this document.

2 Specification of the intended use in accordance with the applicable European Assessment Document (hereinafter EAD)

The intended use of fischer FFB-ES Plus is to reinstate the fire resistance performance of linear joint gaps in rigid wall and floor constructions, and perimeter joints in curtain wall façades.

The specific elements of construction that the system fischer FFB-ES Plus may be used to provide a linear joint seal:

Rigid Walls:

The wall must have a minimum thickness of 150 mm and comprise concrete, aerated concrete, or masonry, with a minimum density of 650 kg/m³.

Rigid Floors:

The floor must have a minimum thickness of 150 mm and comprise concrete or aerated concrete with a minimum density of 650 kg/m³.

The supporting construction must be classified in accordance with EN 13501-2 for the required fire resistance period.

The individual requirements for walls and floors are detailed in the respective systems in Annex B of this document.

fischer FFB-ES Plus may be used to provide a linear joint or gap seal with specific supporting constructions and substrates (for details see Annex B of this document).

More information in table, section 3: "Performance of the product and references to the methods used for its assessment".

fischer FFB-ES Plus is fire tested against EN 1366-4 and EN 1364-4.

The maximum permitted joint/gap width for fischer FFB-ES Plus is 450 mm.

The maximum movement capability of fischer FFB-ES Plus is 25%

The installation guidelines for fischer FFB-ES Plus in the technical datasheet accompanying this product must be followed.

The provisions made in this European Technical Assessment are based on an assumed intended working life of the sealant system of 25 years, provided that the conditions laid down in the product data sheet for the packaging/transport/storage/installation/use/repair are met.

The indications given on the intended working life cannot be interpreted as a guarantee given by the producer or the Technical Assessment Body but are to be regarded only as a means for selecting the appropriate products in relation to the expected economically reasonable working life of the works.

3 Performance of the product and references to the methods used for its assessment.

Characteristic

Assessment of characteristic

3.2 Safety in case of fire (BWR 2)

Reaction to fire

The product is classified as **D-s1, d1** in accordance with EN13501-1, and the EC Delegated regulation 2016/364/EU.

Resistance to fire

See Annex B

3.3 Hygiene, Health and the Environment (BWR 3)

Air permeability

Leakage rate pr unit area of the seal: **Q100 < 0,10 m³/hm**

Water permeability

Clear opening [mm]	Result
Ø 300	Watertight to 600 Pa
550x200	Watertight to 300 Pa
100x1000	Watertight to 600 Pa

Content, emission and/or release of dangerous Substances*

Release scenario: **IA1**

	3 days [µg/m ³]	28 days [µg/m ³]
SVOC	0	0
VOC	< 5	< 5

3.4 Safety and accessibility in use (BWR4)

Mechanical resistance and stability

No performance assessed

Resistance to impact/movement

No performance assessed

Adhesion

Elastic recovery	22%
Loss of volume	-19,5%
Flow of sealants	No performance assessed

Durability

Use category: **Type X**

Movement capability

See Annex B

Cycling of perimeter seals for curtain walls

Cycle tested at **30 cpm**

Compression set

No performance assessed

Linear expansion on setting

No performance assessed

3.5 Protection against noise (BWR5)

Airborne sound insulation

Rw (C; Ctr) = 44 (-4; -9) dB

3.6 Energy economy and heat retention (BWR6)

Thermal properties

No performance assessed

Water vapour permeability

No performance assessed

See additional information in section 3.8-3.9

*) In addition to the specific clauses relating to dangerous substances contained in this European technical Assessment, there may be other requirements applicable to the products falling within its scope (e.g., transposed European legislation and national laws, regulations and administrative provisions). In order to meet the provisions of the Construction Products Regulation, these requirements need also to be complied with, when and where they apply.

3.8 Methods of assessment

The product is fully covered by EAD 350141-00-1106 Firestopping and fire sealing products, Linear Joint Seals and fulfils the requirement for use category: X - Intended for use in conditions exposed to weathering. Products that meet requirements for type X, meet the requirements for all other types.

3.9 General aspects related to the fitness for use of the product.

The European Technical Assessment is issued for the product based on agreed data/information, deposited with ETA-Danmark, which identifies the product that has been assessed and judged. Changes to the product or production process, which could result in this deposited data/information being incorrect, should be notified to ETA-Danmark before the changes are introduced. ETA-Danmark will decide if such changes affect the ETA and consequently the validity of the CE marking based on the ETA and if so whether further assessment or alterations to the ETA, shall be necessary.

The fischer FFB-ES Plus for firestopping and fire sealing purposes are manufactured in accordance with the provisions of this European Technical Assessment using the manufacturing processes as identified in the inspection of the plant by the notified inspection body and laid down in the technical documentation.

4 Attestation and verification of constancy of performance (hereinafter AVCP) system applied, with reference to its legal base.

4.1 AVCP system

According to the decision 1999/454/EC of the European Commission, the system of assessment and verification of constancy of performance (see Annex V to Regulation (EU) No 305/2011) is: **1**.

5 Technical details necessary for the implementation of the AVCP system, as provided for in the applicable EAD.

Technical details necessary for the implementation of the AVCP system are laid down in the control plan deposited at ETA-Danmark prior to CE marking.

Issued in Copenhagen on 2023-11-28 by



Thomas Bruun
Managing Director, ETA-Danmark

Annex A

References

A.1References to standards mentioned in the ETA:

EN 1364-4:2014	Fire resistance tests for non-loadbearing elements - Part 4: Curtain walling - Part configuration
EN 1366-4:2021	Fire resistance tests for service installations - Part 4: Linear joint seals
EN 13501-1:2018	Fire classification of construction products and building elements – Part 1: Classification using test data from reaction to fire tests
EN 13501-2:2016	Fire classification of construction products and building elements – Part 2: Classification using test data from fire resistance tests

A.2Other reference documents:

EAD 350141-00-1106	European Assessment Document: Fire Stopping and Fire Sealing Products, Linear Joint and Gap Seals, September 2017
EOTA TR 024	EOTA Technical Report: Technical description and assessment of reactive products effective in case of fire, Edition November 2006, Amended August 2019
Council Directive 67/548/EEC	Council Directive 67/548/EEC of 27 June 1967 on the approximation of laws, regulations and administrative provisions relating to the classification, packaging and labelling of dangerous substances.

Table of Content

TECHNICAL DETAILS NECESSARY FOR THE IMPLEMENTATION OF THE AVCP SYSTEM ARE LAID DOWN IN THE CONTROL PLAN DEPOSITED AT ETA-DANMARK PRIOR TO CE MARKING.....	6
A.1 REFERENCES TO STANDARDS MENTIONED IN THE ETA:	7
A.2 OTHER REFERENCE DOCUMENTS:	7
TABLE OF CONTENT	8
B.1 HEAD OF WALL CONSTRUCTION WITH RIGID WALL AND FLOOR, THICKNESS OF MINIMUM 150 MM	9
B.1.1 DOUBLE SIDED HEAD OF WALL JOINT SEAL	9
B.2 RIGID WALL CONSTRUCTIONS WITH FLOOR THICKNESS OF MINIMUM 150 MM	10
B.2.1 SINGLE SIDED LINEAR JOINT SEAL IN FLOOR INSTALLED ON TOP SIDE, PARTIALLY INSULATED	10
B.2.2 SINGLE SIDED LINEAR JOINT SEAL IN FLOOR INSTALLED ON TOP SIDE	11
B.3 RIGID FLOOR CONSTRUCTION WITH FLOOR THICKNESS OF MINIMUM 200 MM.....	12
B.3.1 SINGLE SIDED LINEAR JOINT SEAL IN FLOOR INSTALLED ON TOP SIDE, PARTIALLY INSULATED	12
B.4 NON-FIRE RATED CURTAIN WALL FAÇADE ABUTTING RIGID FLOOR WITH FLOOR THICKNESS OF MINIMUM 150 MM.....	13
B.4.1 SINGLE SIDED LINEAR JOINT SEAL AS PERIMETER SEAL IN FLOOR INSTALLED ON TOP SIDE	13

Annex B

Resistance to Fire Classification of fischer FFB-ES Plus

B.1 Head of wall construction with rigid wall and floor, thickness of minimum 150 mm

B.1.1 Double sided head of wall joint seal

Joint Seal: fischer FFB-ES Plus sealant to both sides of the wall as head of wall joint, backed with stone wool, installed flush with surface of wall, rigid wall thickness ≥ 150 mm, with movement capability	
Construction details: <div style="text-align: center; margin-top: 20px;"> </div>	Key: <ol style="list-style-type: none"> 1. FFB-ES Plus 2. Backing Material 3. Floor 4. Wall

Figure not to scale

Table B.1.1

Substrate	Seal thickness	Seal overlap	Movement capability	Backing material	Classification
Concrete floor ($\rho \geq 2400 \text{ kg/m}^3$) / Rigid wall ($\rho \geq 650 \text{ kg/m}^3$)	$\geq 1.6 \text{ mm}^*$	$\geq 13 \text{ mm}$	$\pm 15 \%$	Stone wool, thickness $\geq 150 \text{ mm}$, $\rho \geq 60 \text{ kg/m}^3$, compressed $\geq 40 \%$	EI 180-T-M15-F-W 5 to W 250
			$\pm 25 \%$	Stone wool, thickness $\geq 150 \text{ mm}$, $\rho \geq 60 \text{ kg/m}^3$, compressed $\geq 33 \%$	EI 180-T-M25-F-W 5 to W 200

* wet film thickness

fischer FFB-ES Plus	Annex B.1.1
Double sided head of wall joint seal	of European Technical Assessment ETA-23/0166

B.2.2 Single sided linear joint seal in floor installed on top side

<p>Joint Seal: fischer FFB-ES Plus sealant to top side of the floor, exposure from underside only, backed with stone wool, installed flush with surface of floor, floor thickness ≥ 150 mm, with movement capability</p>	
<p>Construction details:</p> 	<p>Key:</p> <ol style="list-style-type: none"> 1. FFB-ES Plus 2. Backing material 3. Floor

Figure not to scale

Table B.2.2

Substrate	Seal thickness	Seal overlap	Movement capability	Backing material	Classification
Rigid floor ($\rho \geq 650 \text{ kg/m}^3$)	$\geq 1.6 \text{ mm}^*$	$\geq 13 \text{ mm}$	$\pm 25 \%$	Stone wool thickness $\geq 150 \text{ mm}$, $\rho \geq 60 \text{ kg/m}^3$, compressed $\geq 30 \%$	E 240-H-M25-F-W 5 to W 100 EI 180-H-M25-F-W 5 to W 100

* wet film thickness

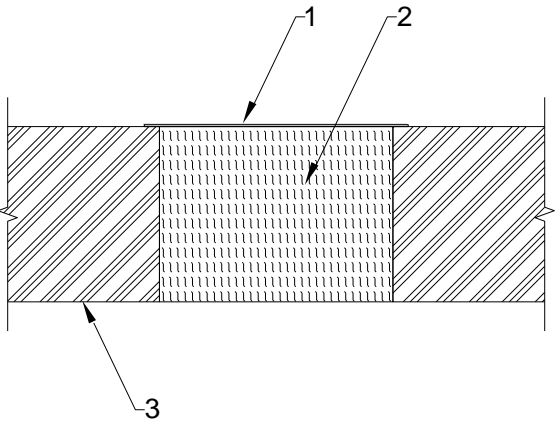
fischer FFB-ES Plus	Annex B.2.2 of European Technical Assessment ETA-23/0166
Single sided linear joint seal in floor installed on top side	

B.3 Rigid floor construction with floor thickness of minimum 200 mm

B.3.1 Single sided linear joint seal in floor installed on top side, partially insulated

<p>Joint Seal: fischer FFB-ES Plus sealant to top side of the floor, exposure from underside only, backed with stone wool, installed flush with surface of floor, floor thickness ≥ 200 mm, with movement capability</p>	
<p>Construction details:</p>  <p style="text-align: center;">Figure not to scale</p>	<p>Key:</p> <ol style="list-style-type: none"> 1. FFB-ES Plus 2. Backing material 3. Floor

Table B.3.1

Substrate	Seal thickness	Seal overlap	Movement capability	Backing material	Classification
Rigid floor ($\rho \geq 2400 \text{ kg/m}^3$)	$\geq 1.6 \text{ mm}^*$	$\geq 13 \text{ mm}$	$\pm 15 \%$	Stone wool thickness $\geq 150 \text{ mm}$, $\rho \geq 60 \text{ kg/m}^3$, compressed $\geq 40 \%$	EI 240-H-M15-F-W 5 to W 200
					E 240-H-M15-F-W 5 to W 300 EI 180-H-M15-F-W 5 to W 300

* wet film thickness

fischer FFB-ES Plus	Annex B.3.1 of European Technical Assessment ETA-23/0166
Single sided linear joint seal in floor installed on top side, partially insulated	

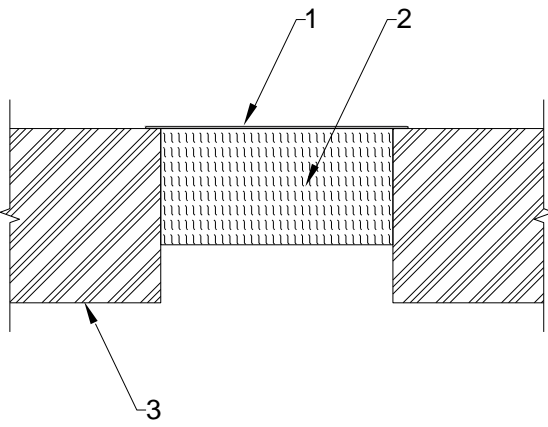
B.4 Non-fire rated curtain wall façade abutting rigid floor with floor thickness of minimum 150 mm

B.4.1 Single sided linear joint seal as perimeter seal in floor installed on top side

<p>Joint Seal: fischer FFB-ES Plus as perimeter seal, exposure from underside only, backed with stone wool, installed flush with surface of floor, floor thickness ≥ 150 mm, with movement capability</p>	
<p>Construction details:</p> 	<p>Key:</p> <ol style="list-style-type: none"> 1. FFB-ES Plus 2. Backing material 3. Curtain wall façade*** 4. Spandrel area**** 5. Floor

Figure not to scale

Table B.4.1

Substrate	Seal thickness	Seal overlap	Movement capability	Backing material	Classification
Curtain wall*** / Concrete ($\rho \geq 2400 \text{ kg/m}^3$)	$\geq 1.6 \text{ mm}^*$	$\geq 13 \text{ mm}$	$\pm 15 \%^{**}$	Stone wool thickness 150 mm, $\rho \geq 60 \text{ kg/m}^3$, compressed $\geq 30 \%$	E 180-H-M15-F-W 5 to W 250 EI 90-H-M15-F-W 5 to W 250

* wet film thickness

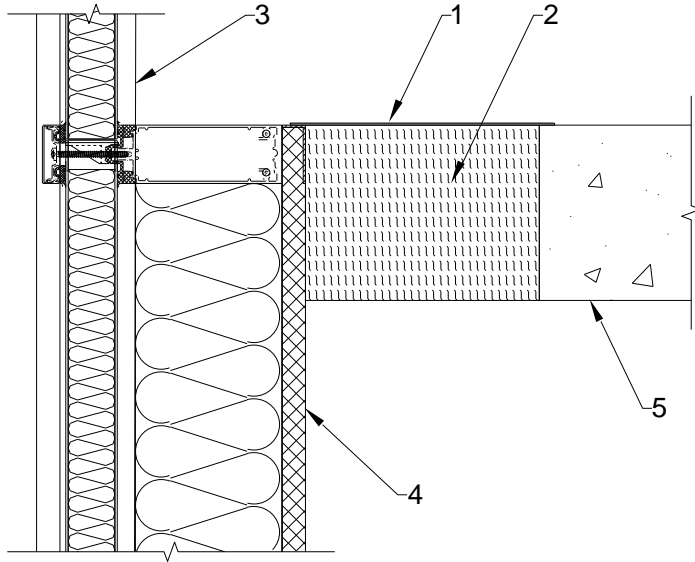
** movement per EAD 350141-00-1106 with 500 cycles at a rate of 30 cycles per minute compression and extension

*** Curtain wall façade (non-fire rated), sloped inside, or sloped outside to a maximum angle of 10° from the vertical axis

****Mineral wool protection of spandrel area, density 150 kg/m^3 , 50 mm thick

fischer FFB-ES Plus	Annex B.4.1 of European Technical Assessment ETA-23/0166
Single sided linear joint seal as perimeter seal in floor installed on top side	