

## DECLARATION OF PERFORMANCE

### DoP-FS-1001

for fischer FIAM Intumescent Acoustic Mastic (Fire stopping and fire sealing products: Penetration Seals)

EN

1. Unique identification code of the product-type: DoP-FS-1001
2. Intended use/es: Maintenance of the fire resistance of a separating element at the position where services pass through, see appendix, especially annexes, 1-2.
3. Manufacturer: fischerwerke GmbH & Co. KG, Klaus-Fischer-Str. 1, 72178 Waldachtal, Germany
4. Authorised representative: -
5. System/s of AVCP: 1
6. European Assessment Document: EAD 350454-00-1104  
European Technical Assessment: ETA-20/1064; 2021-05-10  
Technical Assessment Body: ETA-Danmark A/S  
Notified body/ies: 2531 - DBI Certification A/S
7. Declared performance/s:  
**Safety in case of fire (BWR 2)**  
Reaction to fire: NPD  
Resistance to fire: Annexes 5-22  
  
**Hygiene, health and the environment (BWR 3)**  
Air permeability (material property): Annex 23  
Water permeability (material property): NPD  
Content, emission and/or release of dangerous substances: Annex 3  
  
**Safety and accessibility in use (BWR 4)**  
Mechanical resistance and stability: NPD  
Resistance to impact/movement: NPD  
Adhesion: NPD  
Durability: Annex 3  
  
**Protection against noise (BWR 5)**  
Airborne sound insulation: Annexes 24-25  
  
**Energy economy and heat retention (BWR 6)**  
Thermal properties: NPD  
Water vapour permeability: NPD
8. Appropriate Technical Documentation and/or Specific Technical Documentation: -

The performance of the product identified above is in conformity with the set of declared performance/s. This declaration of performance is issued, in accordance with Regulation (EU) No 305/2011, under the sole responsibility of the manufacturer identified above.

Signed for and on behalf of the manufacturer by:



Dr.-Ing. Oliver Geibig, Managing Director Business Units & Engineering  
Tumlingen, 2021-05-17



Jürgen Grün, Managing Director Chemistry & Quality

This DoP has been prepared in different languages. In case there is a dispute on the interpretation the English version shall always prevail.

The Appendix includes voluntary and complementary information in English language exceeding the (language-neutrally specified) legal requirements.

## I. SPECIFIC PARTS OF THE EUROPEAN TECHNICAL ASSESSMENT

### 1 Technical description of the product

- 1) fischer FiAM Intumescent Acoustic Mastic is an acrylic based sealant used to form a penetration seal around insulated or uninsulated metallic pipes and electrical cables, to reinstate the fire resistance performance of wall and floor constructions where they have been provided with apertures for the penetration of services.
- 2) fischer FiAM Intumescent Acoustic Mastic is supplied in liquid form contained within 310 ml & 380 ml cartridges, 600 ml foils or in 5, 10, 20 or 25 litre tubs. The sealant is gunned or trowelled into the aperture in or between the separating element/elements to a specified depth using various backing materials.
- 3) Certain seals require fischer Thermal Defense Wrap in addition, used to insulate the service. The Thermal Defense Wrap is a 6 mm thick foil faced ceramic based insulation material, installed externally to the fischer FiAM Intumescent Acoustic Mastic sealant as detailed in Annex A.
- 4) The applicant has submitted a written declaration that fischer FiAM Intumescent Acoustic Mastic does not contain substances which have to be classified as dangerous according to article 59 (1, 10) of the Regulation (EC) No 1907/2006 (REACH).

In addition to the specific clauses relating to dangerous substances contained in this European technical Assessment, there may be other requirements applicable to the products falling within its scope (e.g. transposed European legislation and national laws, regulations and administrative provisions). In order to meet the provisions of the Construction Products Regulation, these requirements need also to be complied with, when and where they apply.

- 5) The use category of fischer FiAM Intumescent Acoustic Mastic in relation to BWR 3 (Hygiene, health and environment) is IA2

## **2 Specification of the intended uses of the product in accordance with the applicable European Assessment Document (Hereinafter EAD): EAD 350454-00-1104**

Detailed information and data is given in Annex A.

- 1) The intended use of system fischer FiAM Intumescent Acoustic Mastic is to reinstate the fire resistance performance of flexible and rigid wall constructions and rigid floor constructions where they are penetrated by insulated or uninsulated metallic pipes and electrical cables.
- 2) The specific elements of construction that the system fischer FiAM Intumescent Acoustic Mastic may be used to provide a penetration seal in, are as follows:
  - a. Flexible walls: The wall must have a minimum thickness of 75 mm and comprise steel studs or timber studs\* lined on both faces with minimum 1 layer of 12.5 mm thick boards.
  - b. Rigid walls: The wall must have a minimum thickness of 75 mm and comprise concrete, aerated concrete or masonry with a minimum density of 650 kg/m<sup>3</sup>.
  - c. Rigid floors: The floor must have a minimum thickness of 150 mm and comprise aerated concrete or concrete with a minimum density of 650 kg/m<sup>3</sup>.

\* no part of the penetration seal may be closer than 100 mm to a stud, the cavity must be closed between the penetration seal and the stud, and minimum 100 mm of insulation of class A1 or A2 according to EN 13501-1 must be provided within the cavity between the penetration seal and the stud.

The supporting construction must be classified in accordance with EN 13501-2 for the required fire resistance period.

- 3) The System fischer FiAM Intumescent Acoustic Mastic may be used to provide a penetration seal with specific single insulated metal pipes, uninsulated metal pipes and with specific electrical cables, single or in a bundle (for details see Annex A).
- 4) Apertures in the separating element shall be maximum  $\varnothing$  350 mm or 300 x 300 mm. The annular space/gap around the services shall be infilled with fischer FiAM Intumescent Acoustic Mastic sealant and in some cases utilising various backing materials. For full details, see Annex A.
- 5) The provisions made in this European Technical Assessment are based on an assumed working life of the fischer FiAM Intumescent Acoustic Mastic of 25 years, provided that the conditions laid down in the product datasheet for the packaging/transport/ storage/installation/use/repair are met. The indications given on the working life cannot be interpreted as a guarantee given by the producer or the Technical Assessment Body, but are to be regarded only as a means for choosing the right products in relation to the expected economically reasonable working life of the works.
- 6) Type X: Intended for use in conditions exposed to weathering and all lower classes.

### 3 Performance of the product and references to the methods used for its assessment

Product-type: Intumescent sheet	Intended use: Penetration Seal
Essential characteristic	Product performance
<b>BWR 2 Safety in case of fire</b>	
Reaction to fire	No performance assessed
Resistance to fire	Annex A
<b>BWR 3 Hygiene, health and environment</b>	
Air permeability	Annex B
Water permeability	No performance assessed
Content, emission and/or release of dangerous substances	Use categories: IA2 Declaration of manufacturer
<b>BWR 4 Safety in use</b>	
Mechanical resistance and stability	No performance assessed
Resistance to impact/movement	No performance assessed
Adhesion	No performance assessed
Durability	Type X
<b>BWR 5 Protection against noise</b>	
Airborne sound insulation	Annex C
<b>BWR 6 Energy economy and heat retention</b>	
Thermal properties	No performance assessed
Water vapour permeability	No performance assessed

**4 ASSESSMENT AND VERIFICATION OF CONSTANCY OF PERFORMANCE (HEREINAFTER AVCP) SYSTEM APPLIED, WITH REFERENCE TO ITS LEGAL BASE**

According to the decision 1999/454/EC – Commission Decision of date 22nd June 1999 on the procedure for attesting the conformity of construction products pursuant to Article 20(2) of Council Directive 89/106/EEC as regards fire stopping, fire sealing and fire protective products, published in the Official Journal of the European Union (OJEU) L178/52 of 14/07/1999, (see <https://eur-lex.europa.eu/oj/direct-access.html>) of the European Commission<sup>1</sup>, as amended, the system(s) of assessment and verification of constancy of performance (see Annex V to Regulation (EU) No 305/2011) given in the following table(s) applies (apply).

<b>Product(s)</b>	<b>Intended use(s)</b>	<b>Level(s) or class(es)</b>	<b>System(s)</b>
Fire stopping and Fire Sealing Products	For fire compartmentation and/or fire protection or fire performance	Any	1

---

<sup>1</sup> Official Journal of the European Communities L178/52 of 14/7/1999

# ANNEX A – Resistance to Fire Classification – fischer FiAM Intumescent Acoustic Mastic

## A.1 Flexible and rigid wall constructions with wall thickness of minimum 75 mm

### A.1.1 Double sided penetration seal with cables

**Penetration Seal:** Cables (single) fitted centrally within the aperture, sealed with fischer FiAM Intumescent Acoustic Mastic sealant to both sides of the wall, backed with various backing materials. Minimum separation between penetration seals 200 mm (a2).

Construction details:

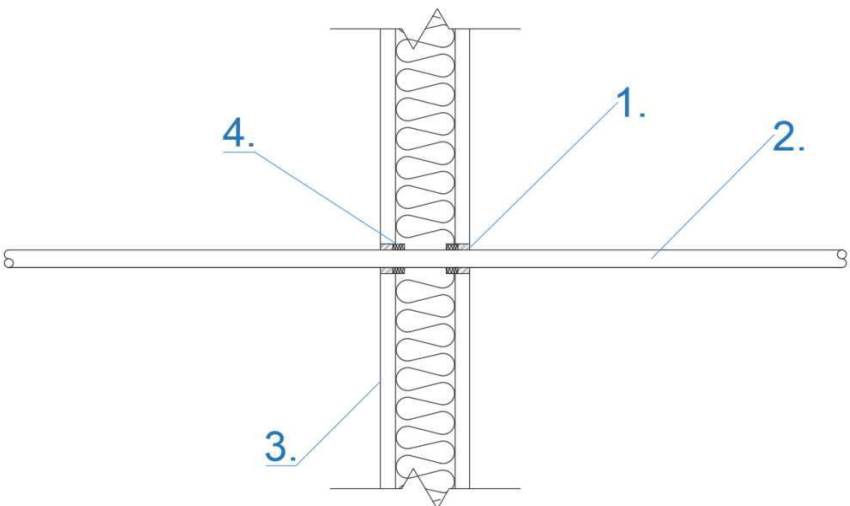

Key:

1. fischer FiAM Intumescent Acoustic Mastic Sealant
2. Single Cable
3. Flexible Wall
4. Backing Material

#### A.1.1.1

Penetration Service	Depth (mm)	Maximum Aperture Size (mm)	Backing Material	Classification
D1 cable*	10	100 Ø	PE backing rod, glass wool, stone wool or ceramic wool	E 60, EI 45
B cable*	12	25 Ø	Stone wool or ceramic wool (10 mm 45kg/m <sup>3</sup> )	E 90, EI 60

\* As defined in EN 1366-3: 2009, Annex A

### A.1.2 Double sided penetration seal with cables bunches

**Penetration Seal:** Cables bunches fitted centrally within the aperture, sealed with fischer FiAM Intumescent Acoustic Mastic Sealant to both sides of the wall, backed with various backing materials. Minimum separation between penetration seals 200 mm (a2).

Construction details:

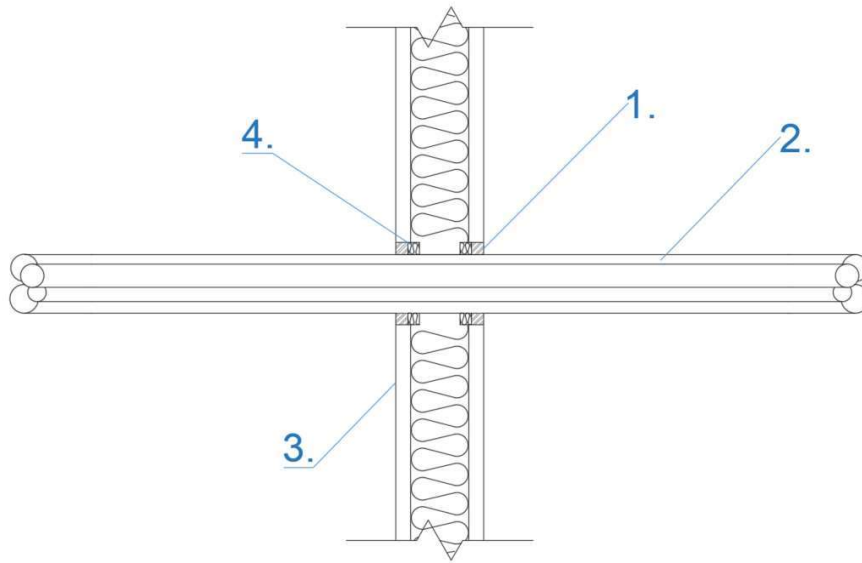

Key:

1. fischer FiAM Intumescent Acoustic Mastic Sealant
2. Single Bunch
3. Flexible Wall
4. Backing Material

#### A.1.2.1

Penetration Service	Depth (mm)	Maximum Aperture Size (mm)	Backing Material	Classification
Telecoms cables $\leq 21$ mm $\varnothing$ in cable bunch $\leq 100$ mm $\varnothing$	10	120 $\varnothing$	PE backing rod, glass wool, stone wool or ceramic wool	<b>E 60, EI 45</b>

### A.1.3 Double sided penetration seal with cable trunking

**Penetration Seal:** Cables trunkings filled with cables penetrating through an aperture through a flexible or rigid wall construction. The aperture is filled with FiP Pillows and sealed with fischer FiAM Intumescent Acoustic Mastic Sealant to both sides of the wall, backed with various backing materials. Minimum separation between penetration seals 200 mm (a2).

Construction details:

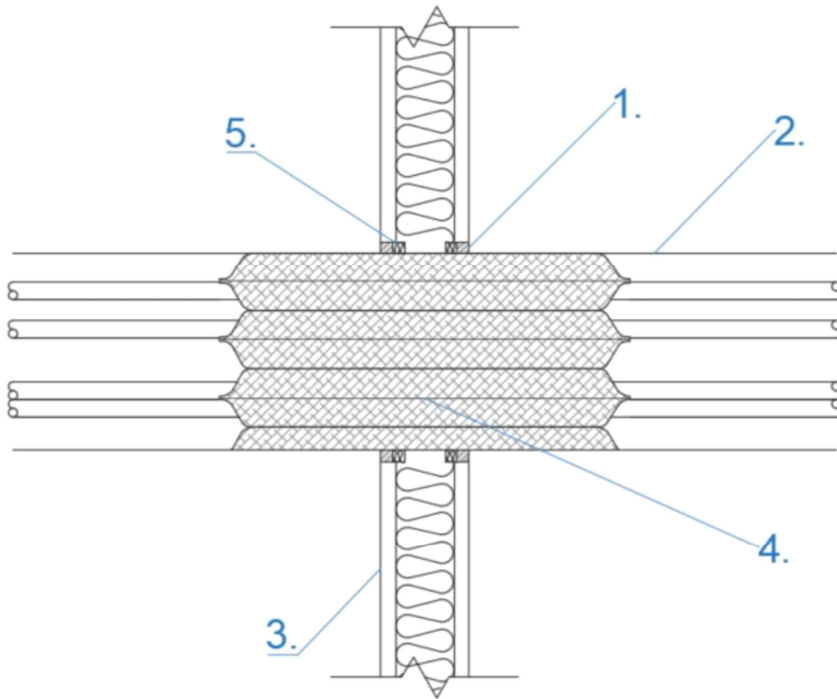

Key:

1. fischer FiAM Intumescent Acoustic Mastic Sealant
2. Metal Trunking filled with cables
3. Flexible Wall
4. fischer Intumescent Pillow FiP
5. Backing Material

#### A.1.3.1

Penetration Service	Depth (mm)	Maximum Aperture Size (mm)	Backing Material	Minimum Distance to Edge of Aperture (mm)	Classification
Steel trunking up to 150 mm x 150 mm	10	170 x 170	PE backing rod, glass wool, stone wool or ceramic wool	0	E 60, EI 20
Steel trunking up to 50 mm x 50 mm	10	70 x 70	PE backing rod, glass wool, stone wool or ceramic wool	0	E 60, EI 45



### A.1.4 Double sided penetration seal with cable trays

**Penetration Seal:** Cables trays with cables penetrating through a flexible or rigid wall construction and sealed with fischer FiAM Intumescent Acoustic Mastic Sealant to both sides of the wall, backed with various backing materials. Minimum separation between penetration seals 200 mm (a2).

Construction details:

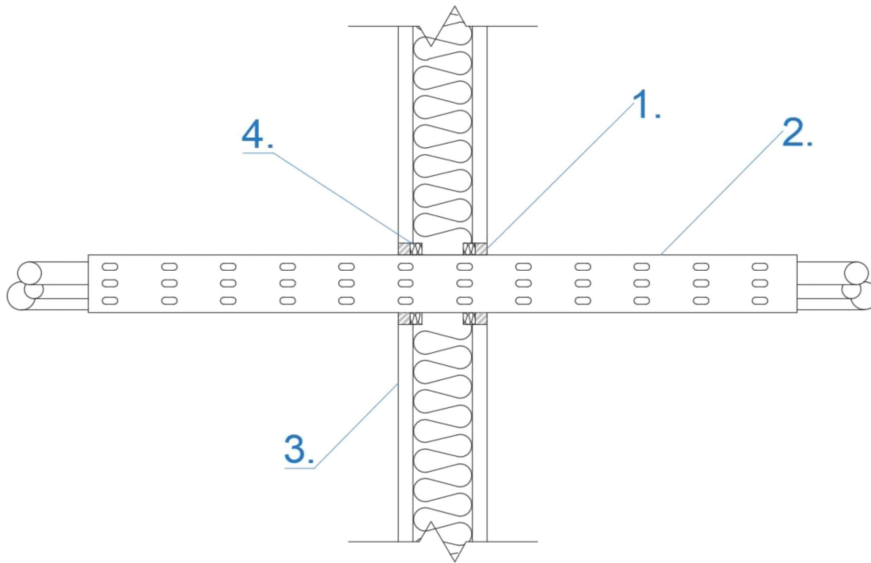

Key:

1. fischer FiAM Intumescent Acoustic Mastic Sealant
2. Cable Tray
3. Flexible Wall
4. Backing Material

#### A.1.4.1

Penetration Service	Depth (mm)	Maximum Aperture Size (mm)	Backing Material	Minimum Distance to Edge of Aperture (mm)	Classification
Steel cable tray ≤450 mm wide loaded with cables ≤21 mm Ø + C1, C2, C3 cables*	10	470 x 100	PE backing rod, glass wool, stone wool or ceramic wool	0	E 60, EI 20
Steel cable tray ≤450 mm wide loaded with cables ≤21 mm Ø + C1, C2, C3 cables* with insulation ≤40 mm thick ≤45kg/m <sup>3</sup> , ≤400 mm either side of the wall (L/I)	10	470 x 100	PE backing rod, glass wool, stone wool or ceramic wool	0	EI 45

\* As defined in EN 1366-3: 2009, Annex A

### A.1.5 Double side penetration seal with metallic pipes

**Penetration Seal:** Metallic pipes (single) fitted centrally within the aperture, sealed with fischer FiAM Intumescent Acoustic Mastic Sealant to both sides of the wall, backed with various backing materials. Minimum separation between penetration seals 200 mm (a2).

Construction details:

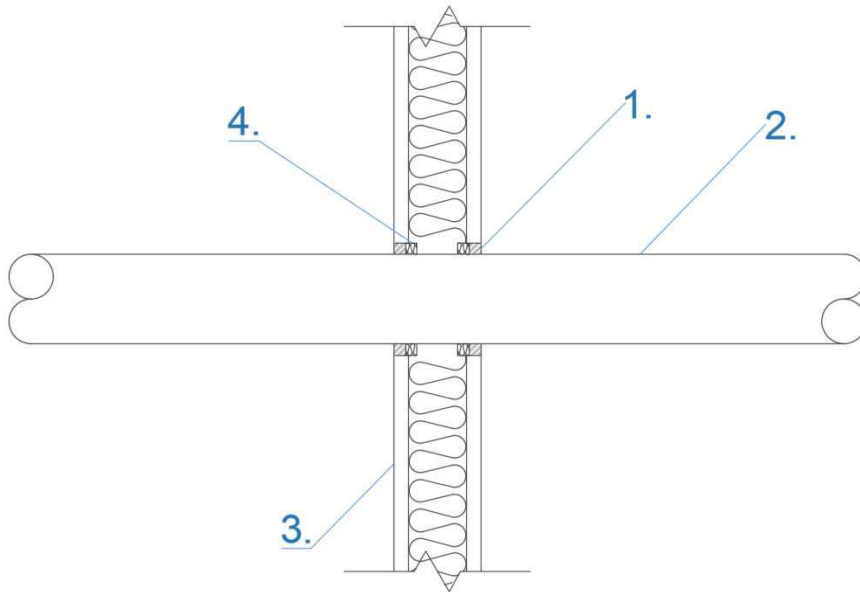

Key:

1. fischer FiAM Intumescent Acoustic Mastic Sealant
2. Metal Pipe
3. Flexible Wall
4. Backing Material

#### A.1.5.1

Penetration Service	Depth (mm)	Annular (mm)	Backing Material	Classification
Copper pipe $\leq 15$ mm diameter/ 0.7-14.2 mm wall thickness	12	5-10	Stone wool or ceramic wool ( $\geq 10$ mm $\geq 45$ kg/m <sup>3</sup> )	E 90 C/U, C/C, EI 60 C/U, C/C
Copper or Steel pipe 15-54 mm diameter/ 1.2-14.2 mm wall thickness*				E 90 C/U, C/C
Steel pipe 15 mm diameter/ 1-14.2 mm wall thickness				EI 90 C/U, C/C
Steel pipe 15-76 mm diameter/ 2-14.2 mm wall thickness*				E 90 C/U, C/C, EI 20 C/U, C/C
Steel pipe 325 mm diameter/ 17.5 mm wall thickness, insulated with stone wool $\geq 40$ mm thick, $\geq 45$ kg/m <sup>3</sup> (LI) min. 400 mm length to both faces	10	25 (0 distance from aperture edge)	PE backing rod, glass wool, stone wool or ceramic wool	E 60 C/U, C/C, EI 30 C/U, C/C

\* See below graphs for interpolated pipe sizes and permitted wall thicknesses

### Copper or Steel Pipes - C/U

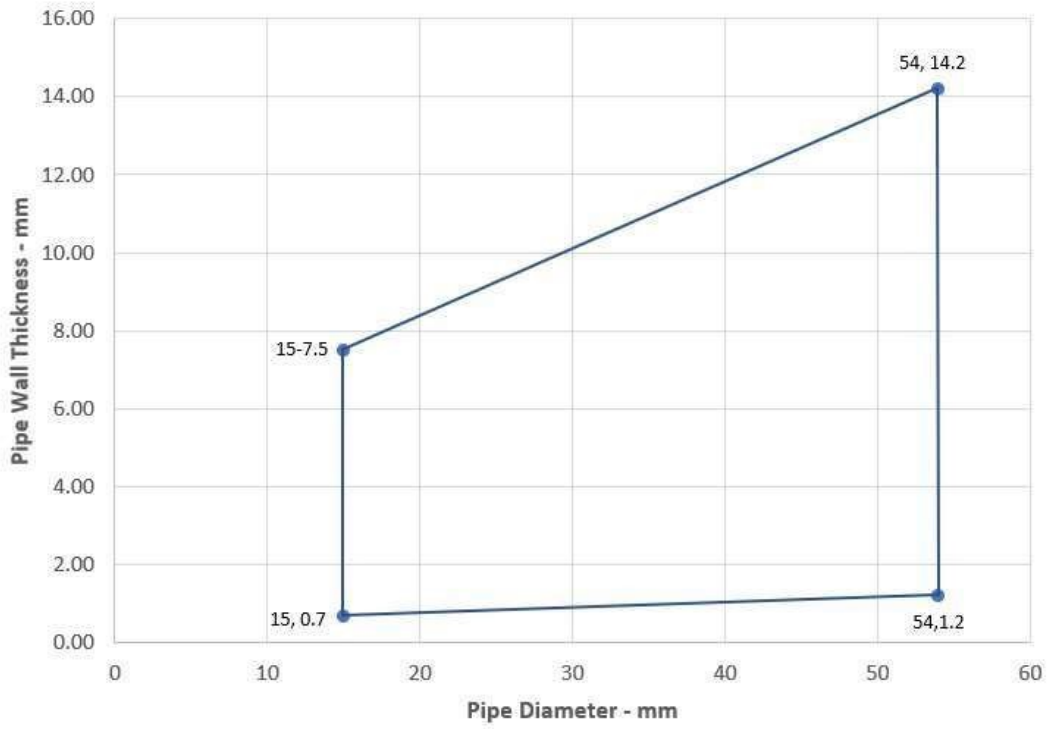

### Steel Pipes - C/U

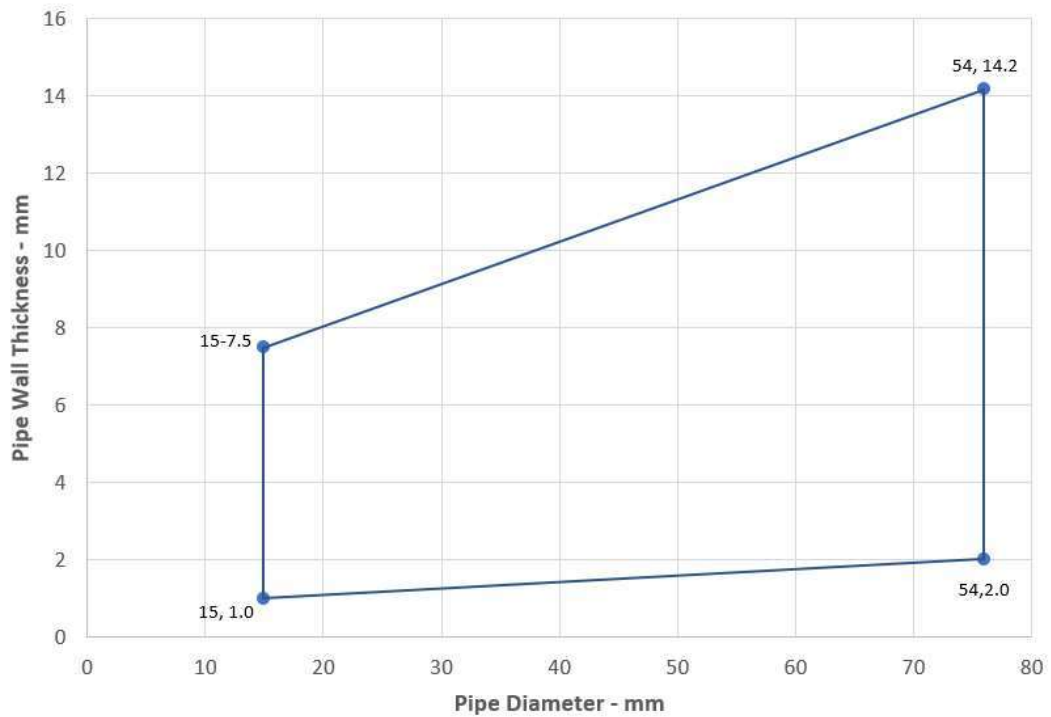

### A.1.6 Double side penetration seal with insulated metallic pipes

**Penetration Seal:** Insulated metallic pipes (single) fitted at any position within the aperture, sealed with fischer FiAM Intumescent Acoustic Mastic Sealant to both sides of the wall, backed with various backing materials. Minimum separation between penetration seals 200 mm (a2).

Construction details:

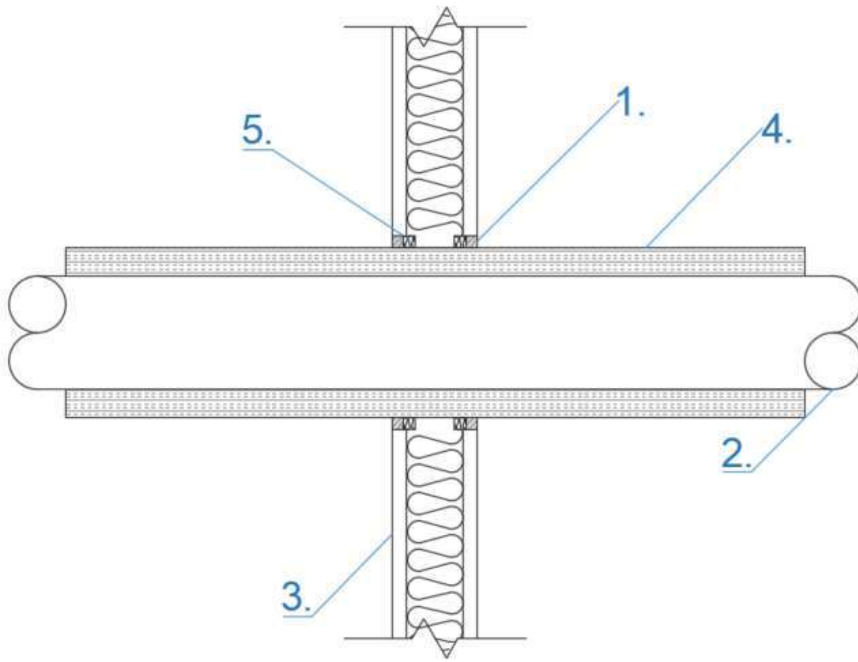

Key:

1. fischer FiAM Intumescent Acoustic Mastic Sealant
2. Metal Pipe
3. Flexible Wall
4. Stone Wool Insulation
5. Backing Material

#### A.1.6.1

Penetration Service	Depth (mm)	Maximum Aperture Size (mm)	Backing Material	Minimum Distance to Edge of Aperture (mm)	Classification
Copper or steel pipe 159 mm diameter/ 2-14.2 mm wall thickness insulated with stone wool $\geq 50$ mm thick, $\geq 90\text{kg/m}^3$ (C/S)	10	10	PE backing rod, glass wool, stone wool or ceramic wool	0	<b>E 60 C/U, C/C, EI 45 C/U, C/C</b>

## A.2 Flexible and rigid wall constructions with wall thickness of minimum 100 mm

### A.2.1 Double sided penetration seal with cables and conduits

**Penetration Seal:** Cables and conduits fitted within the aperture, sealed with fischer FiAM Intumescent Acoustic Mastic Sealant to both sides of the wall, backed with Stone wool or ceramic wool (20 mm 45kg/m<sup>3</sup>). Minimum separation between penetration seals 200 mm (a2).

Construction details:

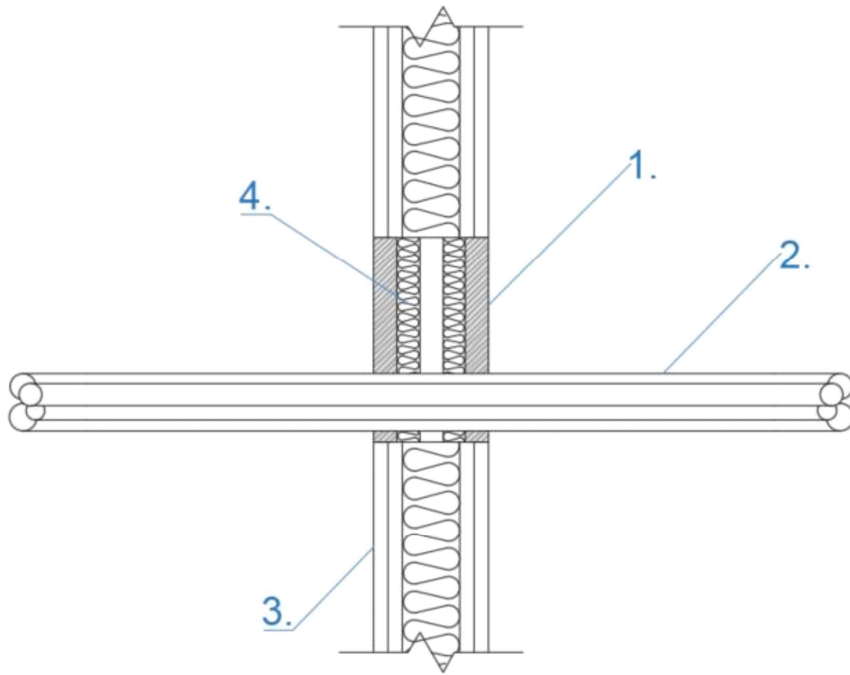

Key:

1. fischer FiAM Intumescent Acoustic Mastic Sealant
2. Cables
3. Flexible Wall
4. Backing Material

#### A.2.1.1

Penetration Service	Depth (mm)	Maximum Aperture Size (mm)	Backing Material	Minimum Distance to Edge of Aperture (mm)	Classification
Cable bunch ≤100 mm Ø	20	180 x 180	Stone wool or ceramic wool (20 mm 45kg/m <sup>3</sup> )	10	EI 120
PVC conduits ≤16 mm Ø					EI 120
Steel/Copper conduits ≤16 mm Ø					E 120, EI 20
Cables ≤50 mm Ø					E 90, EI 60
Cables ≤21 mm Ø					EI 120

## A.2.2 Double sided penetration seal with metallic pipes

**Penetration Seal:** Metallic pipes (single) fitted centrally within the aperture, sealed with fischer FiAM Intumescent Acoustic Mastic Sealant to both sides of the wall, backed with various backing materials. Minimum separation between penetration seals 200 mm (a2).

Construction details:

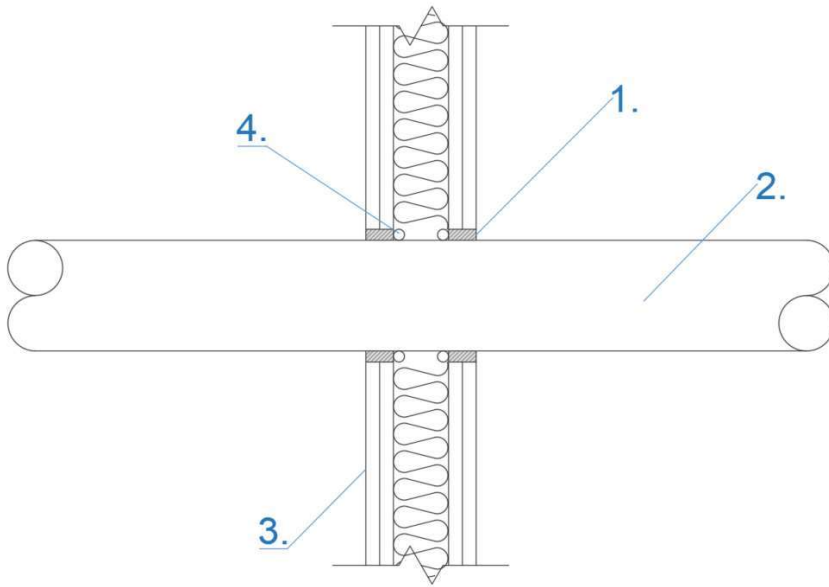

Key:

1. fischer FiAM Intumescent Acoustic Mastic Sealant
2. Metal Pipe
3. Flexible Wall
4. Backing Material

### A.2.2.1

Penetration Service	Depth (mm)	Annular (mm)	Backing Material	Classification
Steel pipe 42 mm diameter/ 2.8-14.2 mm wall thickness	25	10	PE backing rod, glass wool, stone wool or ceramic wool	E 120 C/U, C/C, EI 45 C/U, C/C
Steel pipe 42-114mm diameter/ 3-14.2mm wall thickness*				E 120 C/U, C/C, EI 20 C/U, C/C

\* See below graphs for interpolated pipe sizes and permitted wall thicknesses

**Steel Pipes - C/U**

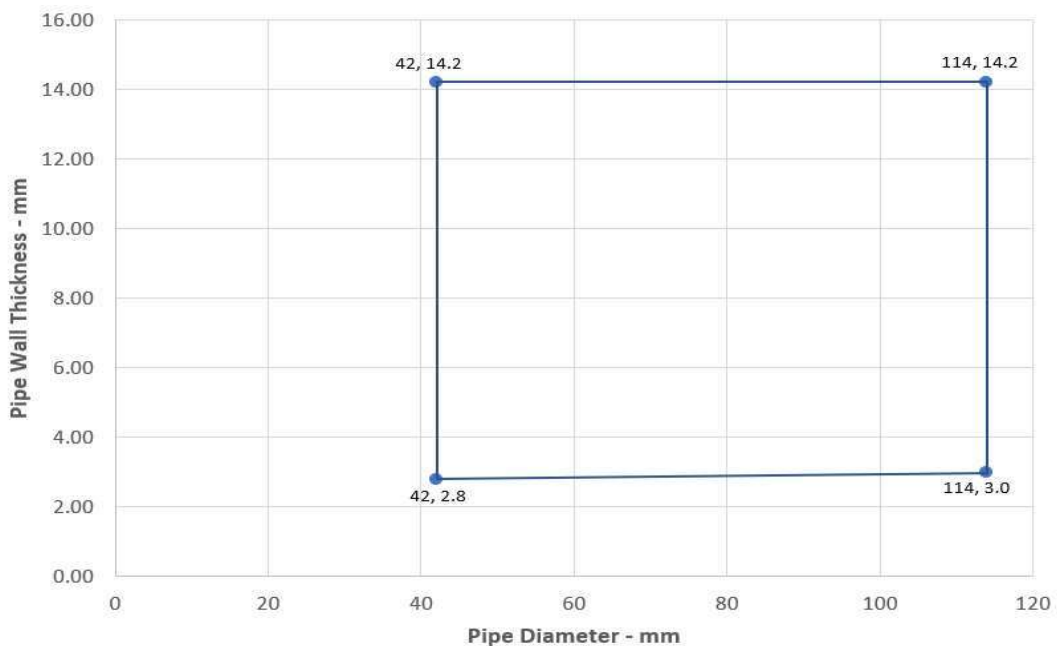

### A.3 Flexible and rigid wall constructions with wall thickness of minimum 120 mm

#### A.3.1 Double sided penetration seal with cable trays

**Penetration Seal:** Cables trays with cables penetrating through a flexible or rigid wall construction and sealed with fischer FiAM Intumescent Acoustic Mastic Sealant to both sides of the wall, backed with various backing materials. Minimum separation between penetration seals 200 mm (a2).

Construction details:

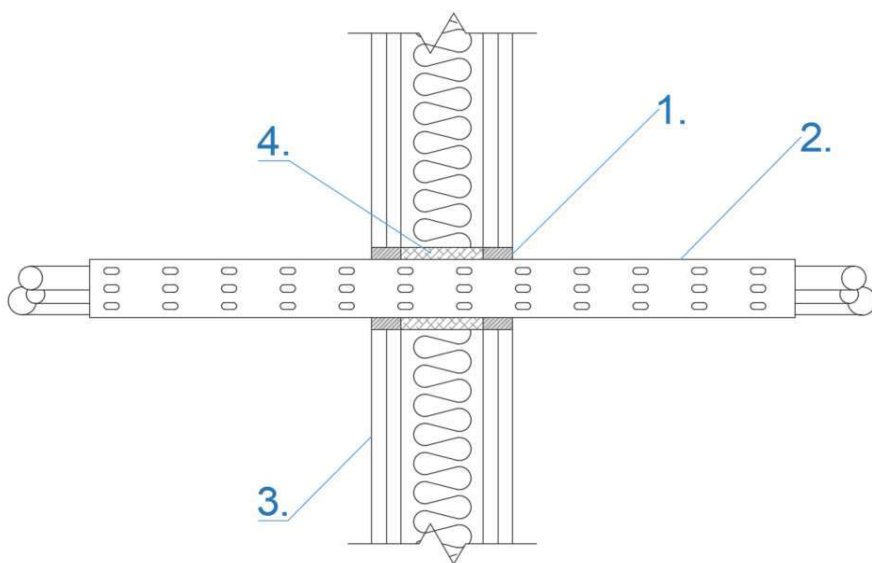

Key:

1. fischer FiAM Intumescent Acoustic Mastic Sealant
2. Cable Tray/Cables
3. Flexible Wall
4. Backing Material

##### A.3.1.1

Penetration Service	Depth (mm)	Maximum Aperture Size (mm)	Backing Material	Minimum Distance to Edge of Aperture (mm)	Classification
Steel cable tray ≤450 mm wide loaded with cables ≤21 mm Ø	25	490 x 100	Stone wool or ceramic wool (≥35 mm ≥80kg/m <sup>3</sup> )	20	<b>E 120, EI 90</b>
C1, C2, D1 and D2 Cables*	25	200 x 100	PE backing rod, glass wool, stone wool or ceramic wool	20	<b>E 90, EI 60</b>

\* As defined in EN 1366-3: 2009, Annex A

### A.3.2 Double sided penetration seal with metallic pipes

**Penetration Seal:** Metallic pipes (single) fitted centrally within the aperture, sealed with fischer FiAM Intumescent Acoustic Mastic Sealant to both sides of the wall, backed with various backing materials. Minimum separation between penetration seals 200 mm (a2).

Construction details:

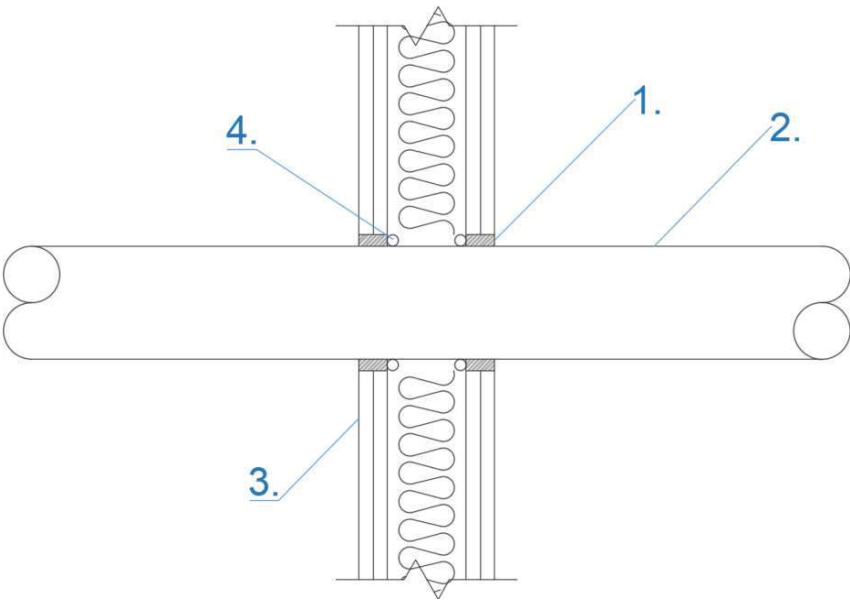

Key:

- fischer FiAM Intumescent Acoustic Mastic Sealant
- Metal Pipe
- Flexible Wall
- Backing Material

#### A.3.2.1

Penetration Service	Depth (mm)	Annular (mm)	Backing Material	Classification
Copper or steel pipe 15-40 mm diameter/ 0.8-14.2 mm wall thickness	25	10	PE backing rod, glass wool, stone wool or ceramic wool	E 120 C/U, C/C, EI 15 C/U, C/C
Copper or steel pipe 40-159 mm diameter/ 1.8-14.2 mm wall thickness*				E 120 C/U, C/C,
Copper or steel pipe 40 mm diameter/ 0.8-14.2mm wall thickness insulated with fischer TDW Thermal Defense Wrap to both sides of the wall at 300 mm (L/I)				E 120 C/U, C/C, EI 90 C/U, C/C
Copper or steel pipe 40-159 mm diameter/ 1.8-14.2 mm wall thickness insulated with fischer TDW Thermal Defense Wrap to both sides of the wall at 300 mm (L/I)*				E 120 C/U, C/C, EI 20 C/U, C/C

\* See below graphs for interpolated pipe sizes and permitted wall thicknesses



### Copper or Steel Pipes - C/U

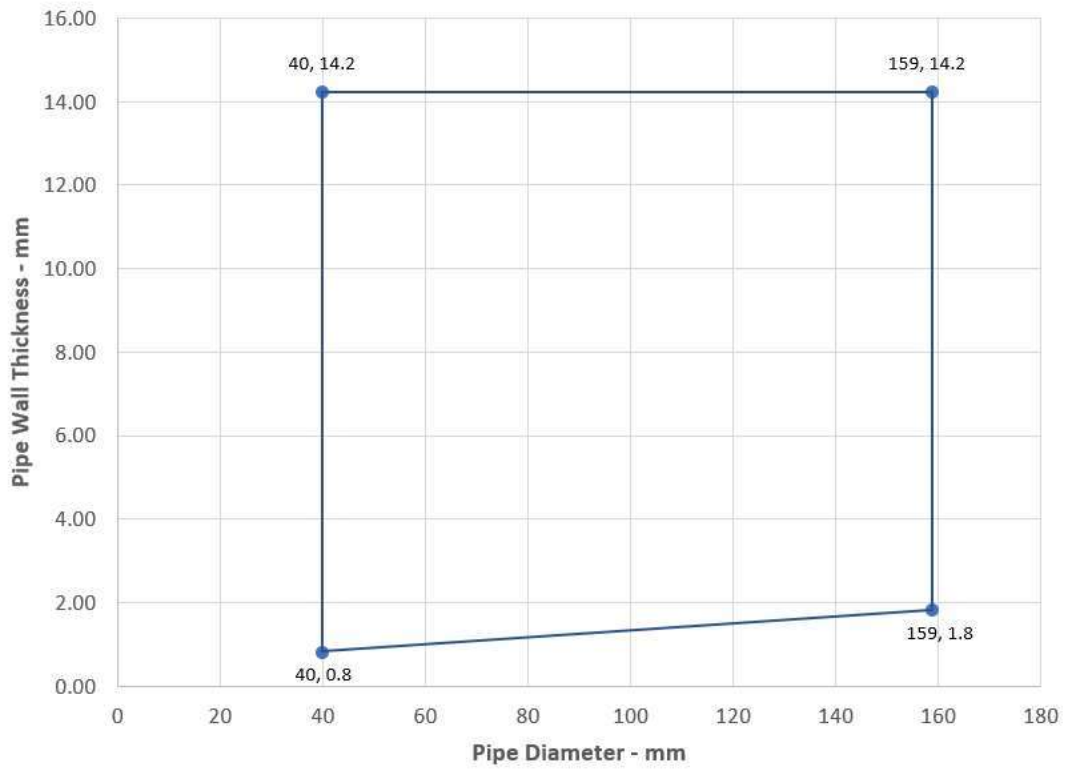

## A.4 Rigid wall constructions with wall thickness of minimum 150 mm

### A.4.1 Double side penetration seal with metallic pipes

**Penetration Seal:** Metallic pipes (single) fitted at any position within the aperture, sealed with fischer FiAM Intumescent Acoustic Mastic Sealant to either side of the wall, backed with Stone wool or ceramic wool ( $\geq 144$  mm  $\geq 80$ kg/m<sup>3</sup>). Minimum separation between penetration seals 200 mm (a2).

Construction details:

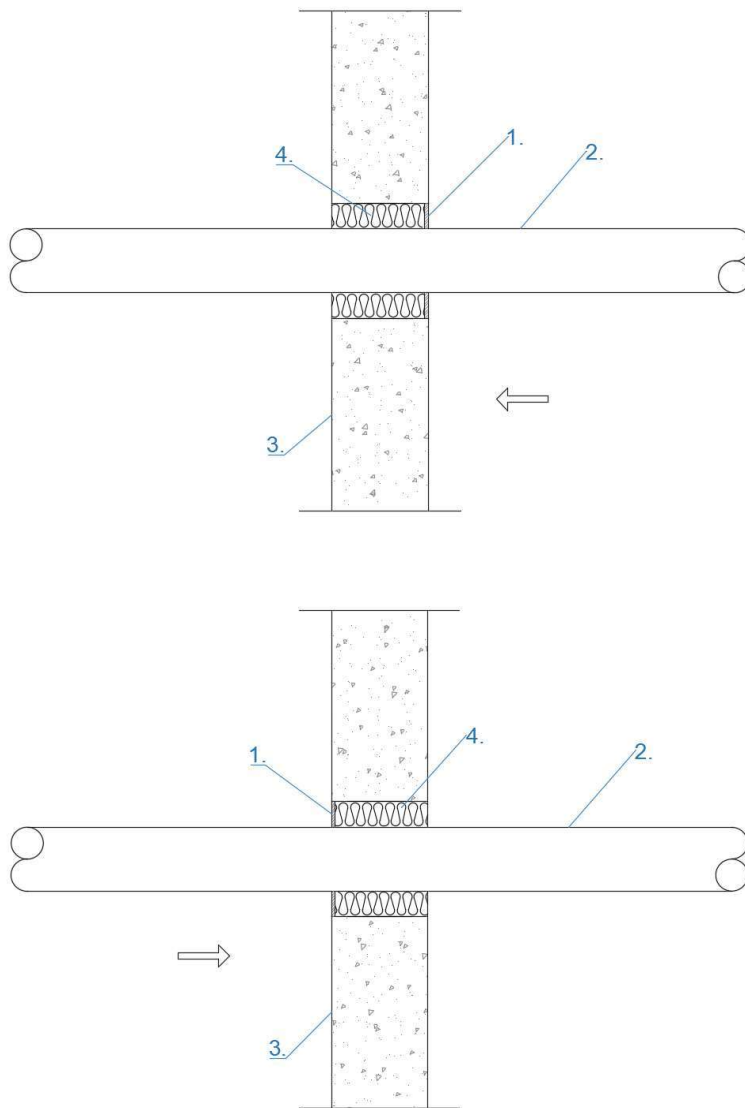

Key:

1. fischer FiAM Intumescent Acoustic Mastic Sealant
2. Metal Pipe
3. Rigid Wall
4. Backing Material

#### A.4.1.1

Penetration Service	Depth (mm)	Maximum Aperture Size (mm)	Backing Material	Minimum Distance to Edge of Aperture (mm)	Classification
Steel pipe 40-152 mm diameter/ 2.5-14.2mm wall thickness*	6	Pipe $\varnothing$ + 50 mm	Stone wool or ceramic wool ( $\geq 144$ mm $\geq 80$ kg/m <sup>3</sup> )	0	E 240 C/C
Steel pipe 40 mm diameter/ 1.5-14.2 mm wall thickness	6	Pipe $\varnothing$ + 50 mm	Stone wool or ceramic wool ( $\geq 144$ mm $\geq 80$ kg/m <sup>3</sup> )	0	E 240 C/C, EI 120 C/C

\* See below graphs for interpolated pipe sizes and permitted wall thicknesses

### Steel Pipes - C/C

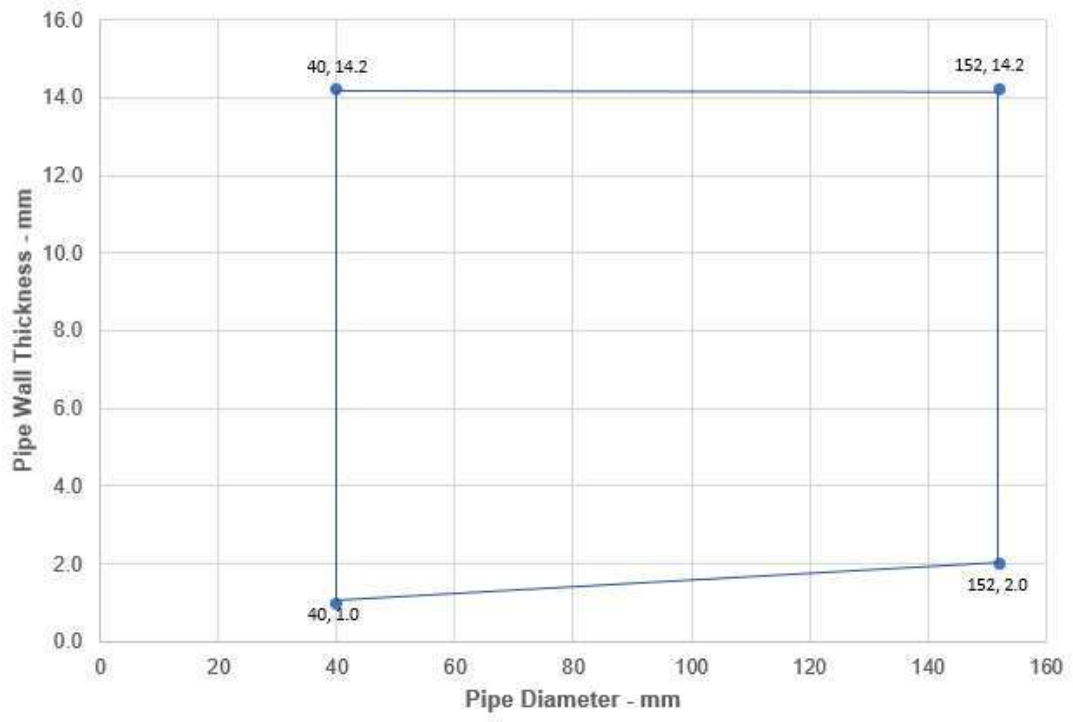

#### A.4.2 Double side penetration seal with insulated metallic pipes

**Penetration Seal:** Insulated metallic pipes (single) fitted at any position within the aperture, sealed with fischer FiAM Intumescent Acoustic Mastic Sealant to both sides of the wall, backed with various backing materials. Minimum separation between penetration seals 200 mm (a2).

Construction details:

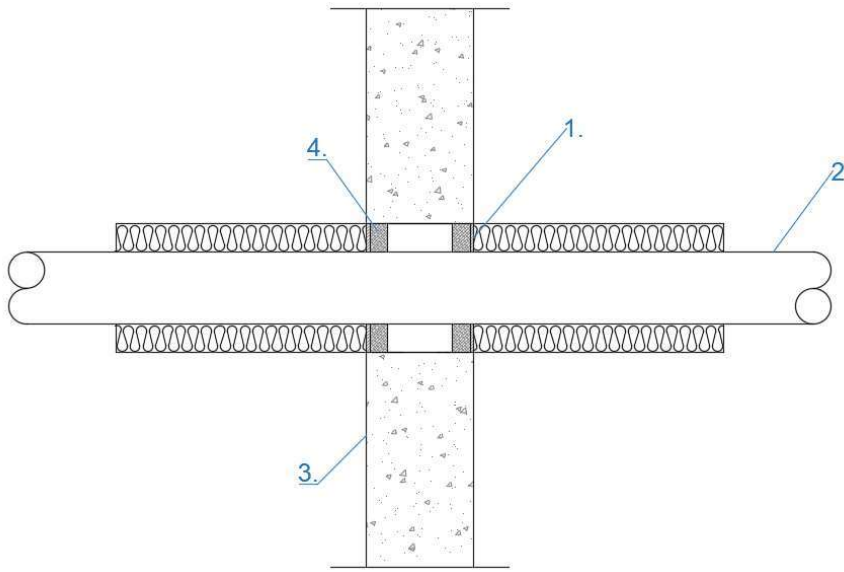

Key:

1. fischer FiAM Intumescent Acoustic Mastic Sealant
2. Metal Pipe
3. Rigid Wall
4. Backing Material

##### A.4.2.1

Penetration Service	Depth (mm)	Maximum Aperture Size (mm)	Backing Material	Minimum Distance to Edge of Aperture (mm)	Classification
Copper or steel pipe 35-159mm diameter/ 2-14.2 mm wall thickness insulated with stone wool 50 mm thick 100kg/m <sup>3</sup> (C/I)*	5	Pipe $\varnothing$ + 55 mm	PE backing rod, glass wool, stone wool or ceramic wool	0	EI 240 C/U, C/C

\* See below graphs for interpolated pipe sizes and permitted wall thicknesses

### Copper or Steel Pipes - C/U

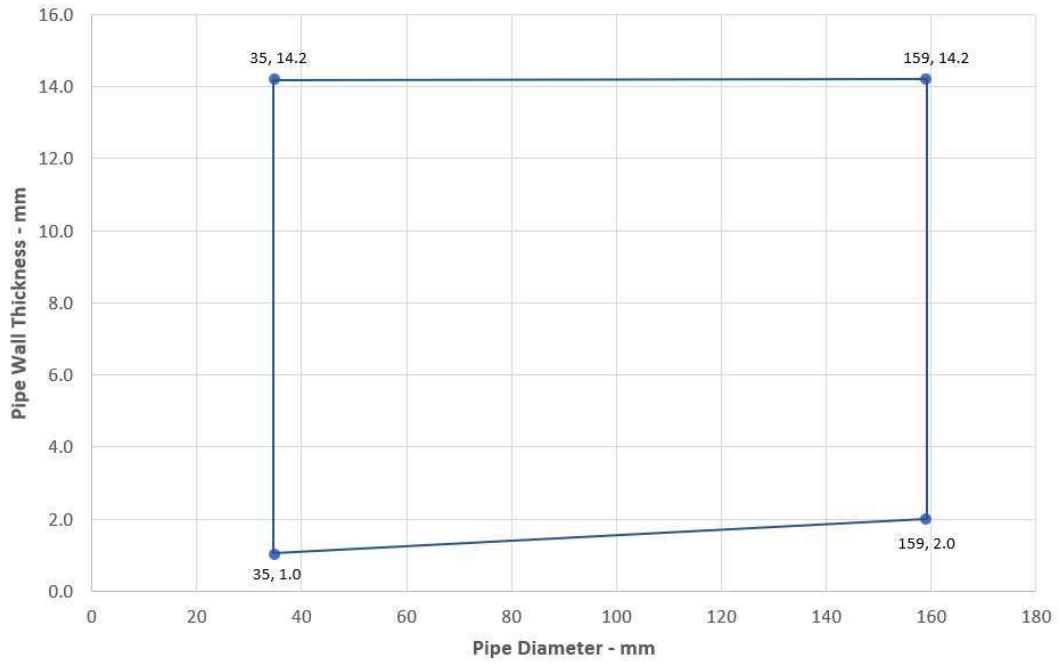

## A.5 Rigid floor constructions with floor depth of minimum 150 mm

### A.5.1 Penetration seal with metallic pipes

**Penetration Seal:** Metallic pipes (single) fitted within the aperture, sealed with fischer FiAM Intumescent Acoustic Mastic Sealant on the top side of the floor, backed with Stone wool or ceramic wool ( $\geq 145 \text{ mm } \geq 45 \text{ kg/m}^3$ ). Minimum separation between penetration seals 200 mm (a2).

Construction details:

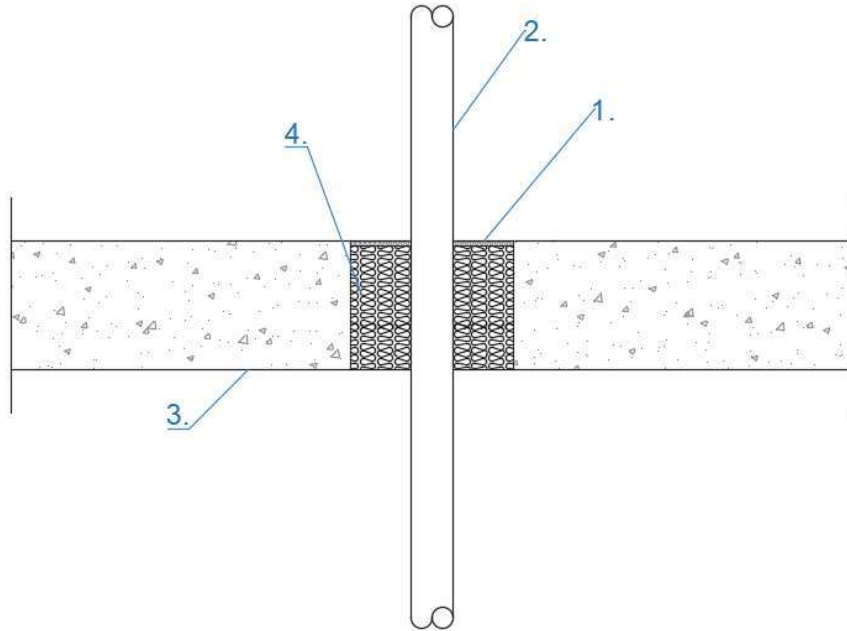

Key:

1. fischer FiAM Intumescent Acoustic Mastic Sealant
2. Metal Pipe
3. Rigid Floor
4. Backing Material

#### A.5.1.1

Penetration Service	Depth (mm)	Maximum Aperture Size (mm)	Backing Material	Minimum Distance to Edge of Aperture (mm)	Classification
Copper or steel pipe 42-159 mm diameter/ 1-14.2 mm wall thickness	5	200 x 200	Stone wool or ceramic wool ( $\geq 145 \text{ mm } \geq 45 \text{ kg/m}^3$ )	20	E 180 C/U, C/C
Copper or steel pipe 42 mm diameter/ 1-14.2 mm wall thickness					E 240 C/U, C/C

## A.5.2 Penetration seal with cables

**Penetration Seal:** Cables and conduits fitted at any position within the aperture, sealed with fischer FiAM Intumescent Acoustic Mastic Sealant to the top side of the floor, backed with Stone wool or ceramic wool ( $\geq 145 \text{ mm} \geq 45 \text{ kg/m}^3$ ). Minimum separation between penetration seals 200 mm (a2).

Construction details:

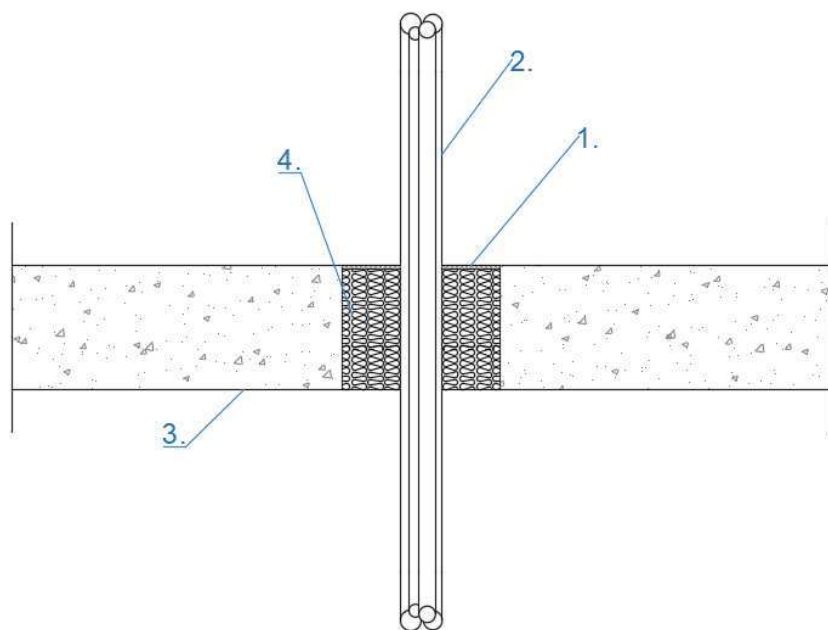

Key:

1. fischer FiAM Intumescent Acoustic Mastic Sealant
2. Cables
3. Rigid Floor
4. Backing Material

### A.5.2.1

Penetration Service	Depth (mm)	Maximum Aperture Size (mm)	Backing Material	Minimum Distance to Edge of Aperture (mm)	Classification
Telecoms cables $\leq 21$ mm diameter in cable bunch $\leq 100$ mm diameter	5	200 x 200	Stone wool or ceramic wool ( $\geq 145 \text{ mm} \geq 45 \text{ kg/m}^3$ )	0	E 45, EI 15
PVC conduits $\leq 16$ mm diameter					E 45, EI 15
Steel or copper conduits $\leq 16$ mm diameter					E 45, EI 15
Cables $\leq 80$ mm diameter					E 90, EI 45
Cables $\leq 50$ mm diameter					E 90, EI 45
Cables $\leq 21$ mm diameter					E 240, EI 90

## ANNEX B – Air Permeability - fischer FiAM Intumescent Acoustic Mastic

Product tested	25 mm thick x 30 mm wide fischer FiAM Intumescent Acoustic Mastic intumescent sealant		
Summary of testing procedure		Result	
	Pressure (Pa)	Leakage (m <sup>3</sup> /h)	Leakage (m <sup>3</sup> /m <sup>2</sup> /h)
Results under negative chamber pressure	50	0.0	0.0
	100	0.0	0.0
	150	0.1	2.8
	200	0.1	2.8
	250	0.1	2.8
	300	0.0	0.0
	450	0.1	2.8
	600	0.1	2.8
Results under positive chamber pressure	50	0.0	0.0
	100	0.0	0.0
	150	0.0	0.0
	200	0.0	0.0
	250	0.0	0.0
	300	0.0	0.0
	450	0.1	2.8
	600	0.1	2.8



# ANNEX C – Airborne Sound Insulation - fischer FiAM Intumescent Acoustic Mastic

## C.1 fischer FiAM Intumescent Acoustic Mastic sealant at 15 mm deep in the following configuration

### FiAM MASTIC SEALANT TESTED TO EN 10140-2:2010 THROUGH A FLEXIBLE CONSTRUCTION

ACOUSTIC TEST RESULTS	
Partition & Sealant Result	63 Rw dB
Sealant Result	51 Rw dB
Sealant Result	61 Dnew dB

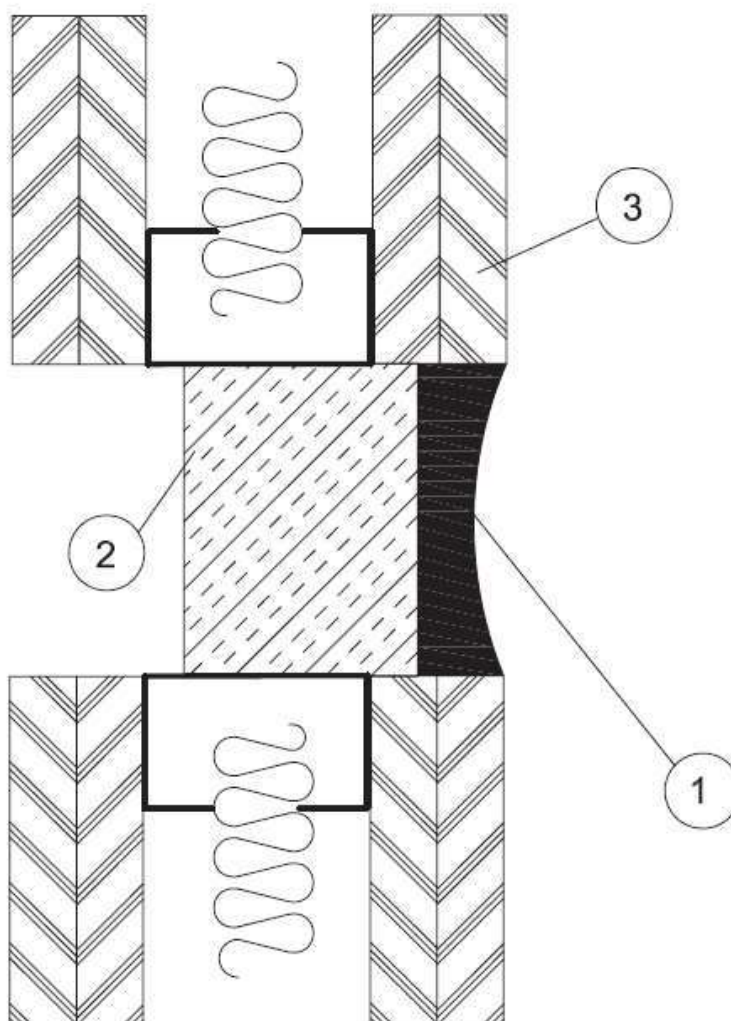

- 1 - FiAM MASTIC SEALANT TO ONE SIDE OF WALL 15mm DEPTH
- 2 - 55mm DEPTH STONE WOOL 60kg DENSITY
- 3 - CONSTRUCTING ELEMENT RATED TO 65 dB

#### BWR 5 Protection against noise

Assessment method	Essential characteristic	Product performance
EN 10140-1,2,4,5/ EN ISO 717-1	Airborne sound insulation	Rw (C;Ctr)= 63(-1;-7)

C.2 fischer FiAM Intumescent Acoustic Mastic sealant at 25 mm deep in the following configuration

FiAM MASTIC SEALANT TESTED TO EN 10140-2:2010 THROUGH A FLEXIBLE CONSTRUCTION

ACOUSTIC TEST RESULTS	
Partition & Sealant Result	63 Rw dB
Sealant Result	51 Rw dB
Sealant Result	61 Dnew dB

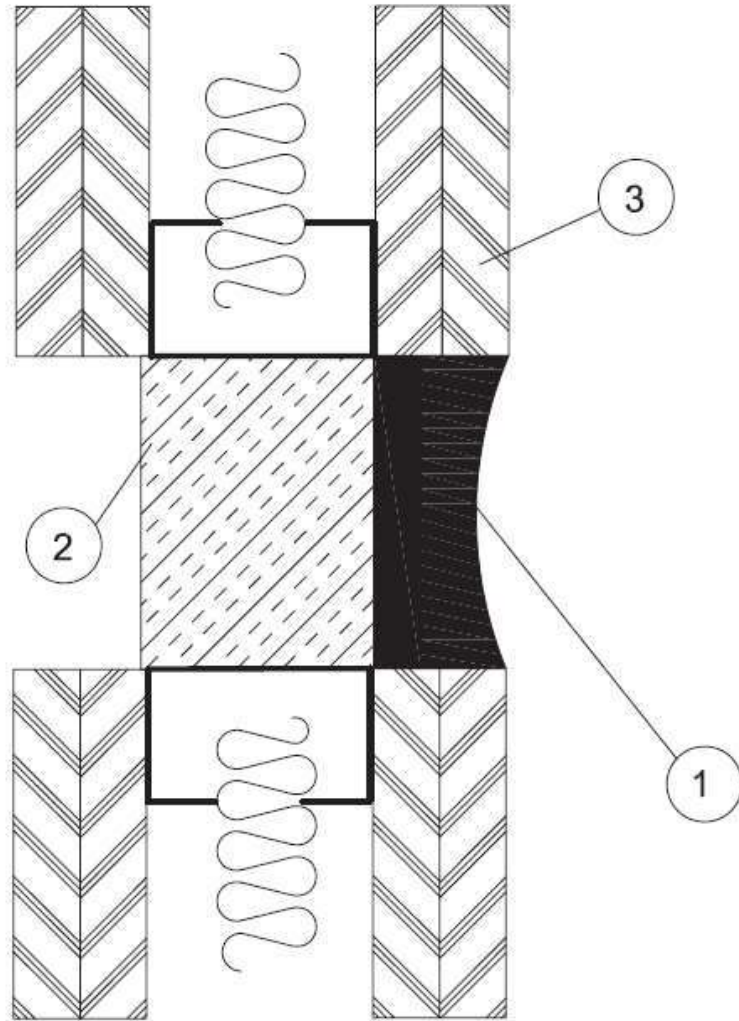

- 1 - FiAM MASTIC SEALANT TO ONE SIDE OF WALL 25mm DEPTH
- 2 - 55mm DEPTH STONE WOOL 60kg DENSITY
- 3 - CONSTRUCTING ELEMENT RATED TO 65 dB

BWR 5 Protection against noise		
Assessment method	Essential characteristic	Product performance
EN 10140-1,2,4,5/ EN ISO 717-1	Airborne sound insulation	Rw (C;Ctr)= 63(-1;-7)